

Gravity Inversion Therapy Table

Owner's Manual

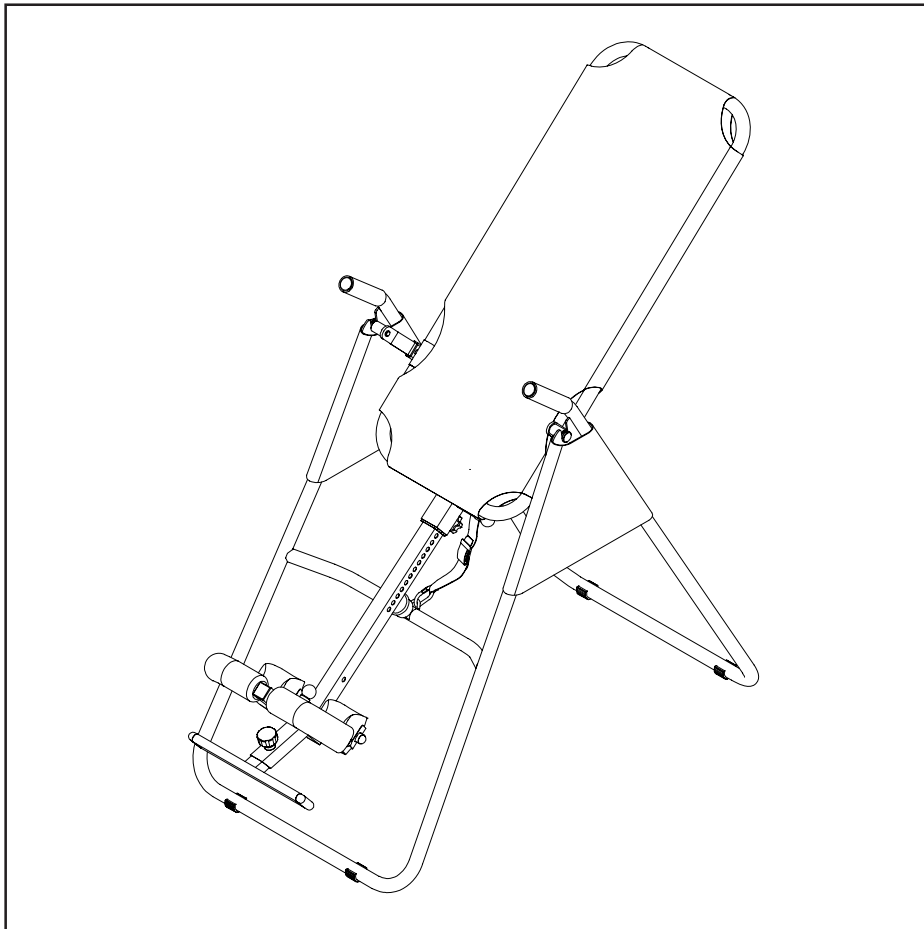

⚠ WARNING ⚠

Exercise can present a health risk. Consult a physician before beginning any exercise program with this equipment. If you feel faint or dizzy, immediately discontinue use of this equipment. Serious bodily injury can occur if this equipment is not assembled and used correctly. Serious bodily injury can also occur if all instructions are not followed. Keep others and pets away from equipment when in use. Always make sure all bolts and nuts are tightened prior to each use. Follow all safety instructions in this manual.

When calling for parts or service, please specify the following number.

CAUTION: 1. Weight on this product should not exceed 250 lbs.
2. Class H equipment: This equipment is for home use only. It is not for commercial use.

MODEL NUMBER
55-1532A
STAMINA PRODUCTS
MADE IN CHINA

Product May Vary Slightly
From Pictured.

This Product is Produced Exclusively by



2040 N. Alliance, Springfield, MO 65803
Customer Service Number
1 (800) 375-7520
www.staminaproducts.com

TABLE OF CONTENTS

	Page		Page
Safety Instructions	2	Maintenance Instructions	13
Before You Begin	4	Product Parts Drawing	14
Hardware Identification Chart	5	Parts List	15
Assembly Instructions	6	Warranty	16
Operational Instructions	10	Notes	17
Storage	13	Fax/Mail Ordering Form	18

SAFETY INSTRUCTIONS

WARNING: To reduce the risk of serious injury, read the following safety instructions before using the Gravity Inversion Therapy Table.

1. Read all warnings posted on the **Gravity Inversion Therapy Table**.
2. The **Gravity Inversion Therapy Table** should only be used after a thorough review of the Owner's Manual.
3. We recommend that two people be available for assembly of this product.
4. Do not use the **Gravity Inversion Therapy Table** alone. Always have a helper available in case assistance is needed in recovering from the inverted position.
5. Verify that a adequate head clearance is available between the user's head and the floor before using this inversion table. This is especially important for tall users.
6. Make sure that the Pivot Arms are assembled to the Main Frame using the same position hole in each Pivot Arm. Pay close attention to Steps 3 and 4 on page 7.
7. Make sure that the PivotArms are always secured to the pegs on the Main Frame with the Bolts and Washers.
8. Adjust the Nylon Straps to limit the Main Frame rotation to an angle of 15 to 20 degrees from the top position and use this setting until you have verified your height setting and become familiar with the **Gravity Inversion Therapy Table**.
9. Use the lowest holes in the Pivot Arms until you become familiar with the **Gravity Inversion Therapy Table**.
10. You must understand how to recover from the fully inverted position before going the fully inverted. Read the **RECOVERY FROM LOCKED POSITION** section at the bottom of page 12 **BEFORE** going the fully inverted.
11. Do not allow children to use or play on the **Gravity Inversion Therapy Table**.
12. Keep small children and pets away from the **Gravity Inversion Therapy Table** at all times.
13. The **Gravity Inversion Therapy Table** should not be used by persons weighing more than 250 lbs.
14. The **Gravity Inversion Therapy Table** should not be used by persons over 6 feet 6 inches tall.
15. It is recommended that you place this exercise equipment on an equipment mat.
16. Use the **Gravity Inversion Therapy Table** only on a level surface.
17. Wear appropriate clothing when exercising; do not wear loose clothing that could become caught in the **Gravity Inversion Therapy Table**.
18. Be sure that there is enough room for the bed to rotate completely.
19. Use the **Gravity Inversion Therapy Table** only as described in the manual.
20. The safety level of the **Gravity Inversion Therapy Table** can be maintained only if it is examined regularly for damage and wear.
21. This equipment is for home use only. It is not for commercial use.

WARNING: Before using this equipment you should consult with your personal physician to see if inversion therapy is appropriate for you. **Do not use this equipment without your physician's approval.** Do not use this equipment if you have any of the following conditions or ailments:

- **Extreme obesity**
- **Glaucoma, retinal detachment or conjunctivitis**
- **Pregnancy**
- **Spinal injury, Cerebral Sclerosis, or acutely swollen joints**
- **Middle ear infection**
- **High blood pressure, Hypertension, Recent stroke or Transient ischemic attack**
- **Heart or circulatory disorders for which you are being treated**
- **Hiatus hernia or Ventral hernia**
- **Bone weaknesses including Osteoporosis, Unhealed fractures, Medullary pins, or Surgically implanted orthopedic supports.**
- **Use of anti-coagulants including Aspirin in high doses.**

CALL US FIRST



CUSTOMER SERVICE NUMBER 1 (800) 375-7520

**THANK YOU FOR PURCHASING THE
Gravity Inversion Therapy Table**

To help you get started, we have pre-assembled most of your Gravity Inversion Therapy Table at the factory with the exception of those few parts left unassembled for shipping purposes. Simply follow the few assembly instructions set forth in this manual. Within a few minutes you will be getting your body into shape and on your way to achieving a happier and healthier lifestyle.

Should you have any questions,
please call our Customer Service Department toll-free number,
1 (800) 375-7520

**Monday - Thursday, 7:30 A.M. - 5:00 P.M. Central Time.
Friday, 8:00 A.M. - 3:00 P.M., Central Time.**



TELEPHONE
CUSTOMER SERVICE
Tel: 1 (800) 375-7520



FAX
CUSTOMER SERVICE
Fax: (417) 889-8064



ONLINE
CUSTOMER SERVICE
parts@staminaproducts.com
cust-srvc@staminaproducts.com
www.staminaproducts.com



MAIL
STAMINA PRODUCTS, INC.
ATTN: Customer Service
P.O. Box 1071
Springfield, MO. 65801-1071

BEFORE YOU BEGIN

Thank you for choosing the **Gravity Inversion Therapy Table**. We take great pride in producing this quality product and hope it will provide many hours of quality exercise to make you feel better, look better and enjoy life to its fullest.

Yes, it's a proven fact that a regular exercise program can improve your physical and mental health. Too often, our busy life styles limit our time and opportunity to exercise. The **Gravity Inversion Therapy Table** provides a convenient and simple method to begin your assault on getting your body in shape and achieving a happier and healthier lifestyle.

Before reading further, please review the drawing below and familiarize yourself with the parts that are labeled.

For your benefit, read this manual carefully before using the **Gravity Inversion Therapy Table**.

Although Stamina manufactures its products with the finest materials and uses the highest standards of manufacturing, occasionally a part that does not fit, is the incorrect size, or is otherwise inappropriate is found. Even with the highest inspection and quality controls in place, these things will happen occasionally. Please do not return the product. Contact us **FIRST!**

If a part is missing or defective, please call us toll free at 1-800-375-7520 (in the U.S.). Our Customer Service Staff is available to assist you from 7:30 A.M. to 5:00 P.M. (Central Time) Monday through Thursday and 8:00 A.M. to 3:00 P.M. (Central Time) on Friday.

If you would like to contact us on-line, go to our website at www.staminaproducts.com and access the Customer Service section or e-mail us at parts@staminaproducts.com.

Be sure to have the name and model number of the product available when you contact us.

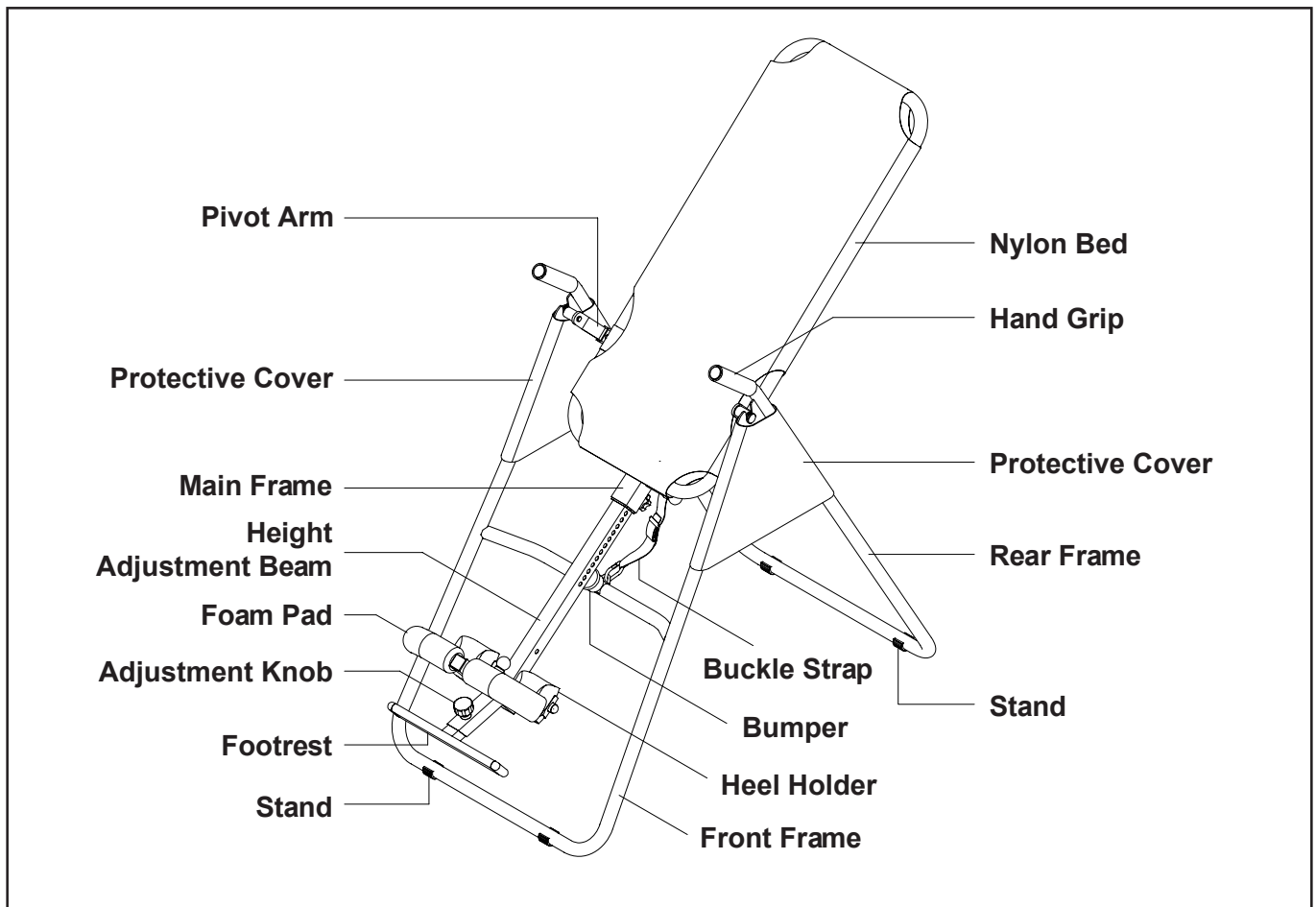

THE FOLLOWING TOOLS ARE INCLUDED FOR ASSEMBLY :

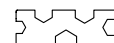

Wrench

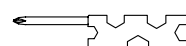

Combination Wrench

HARDWARE IDENTIFICATION CHART

This chart is provided to help identify the hardware used in the assembly process. Place the washers, the end of the bolts, or screws on the circles to check for the correct diameter. Use the small scale to check the length of the bolts and screws.

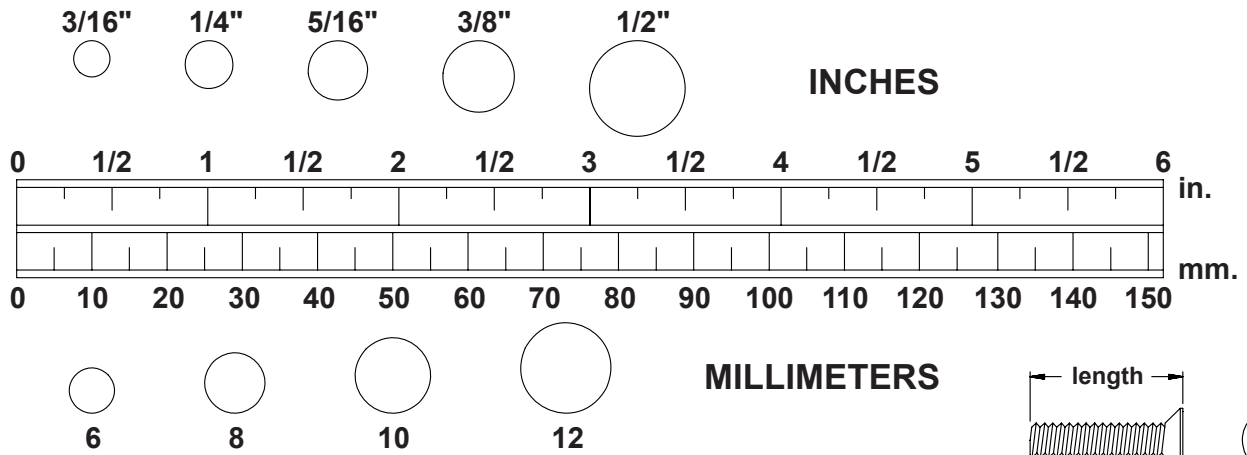

NOTICE: The length of all bolts and screws except those with flat heads is measured from below the head to the end of the bolt or screw. Flat head bolts and screws are measured from the top of the head to the end of the bolt or screw.

After unpacking the unit, open the hardware bag and make sure that you have all the following items. Some hardware may be already attached to the part.

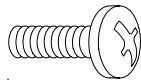

Part No. and Description	Qty
38 Bolt, Round Head (M6 x 1 x 10mm)	2

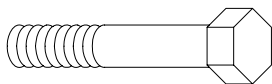

40 Bolt, Hex Head (M6 x 1 x 47mm)	2
-----------------------------------	---

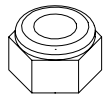

42 Nylock Nut (M6 x 1)	2
------------------------	---

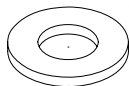

44 Larger Washer (M6)	2
-----------------------	---

45 Washer (M6)	4
----------------	---

ASSEMBLY INSTRUCTIONS

Place all parts from the box in a cleared area and position them on the floor in front of you. Remove all packing materials from your area and place them back into the box. Do not dispose of the packing materials until assembly is completed. Read each step carefully before beginning. If you are missing a part please call our toll-free number for assistance **1 (800) 375-7520** or e-mail us at:

parts@staminaproducts.com

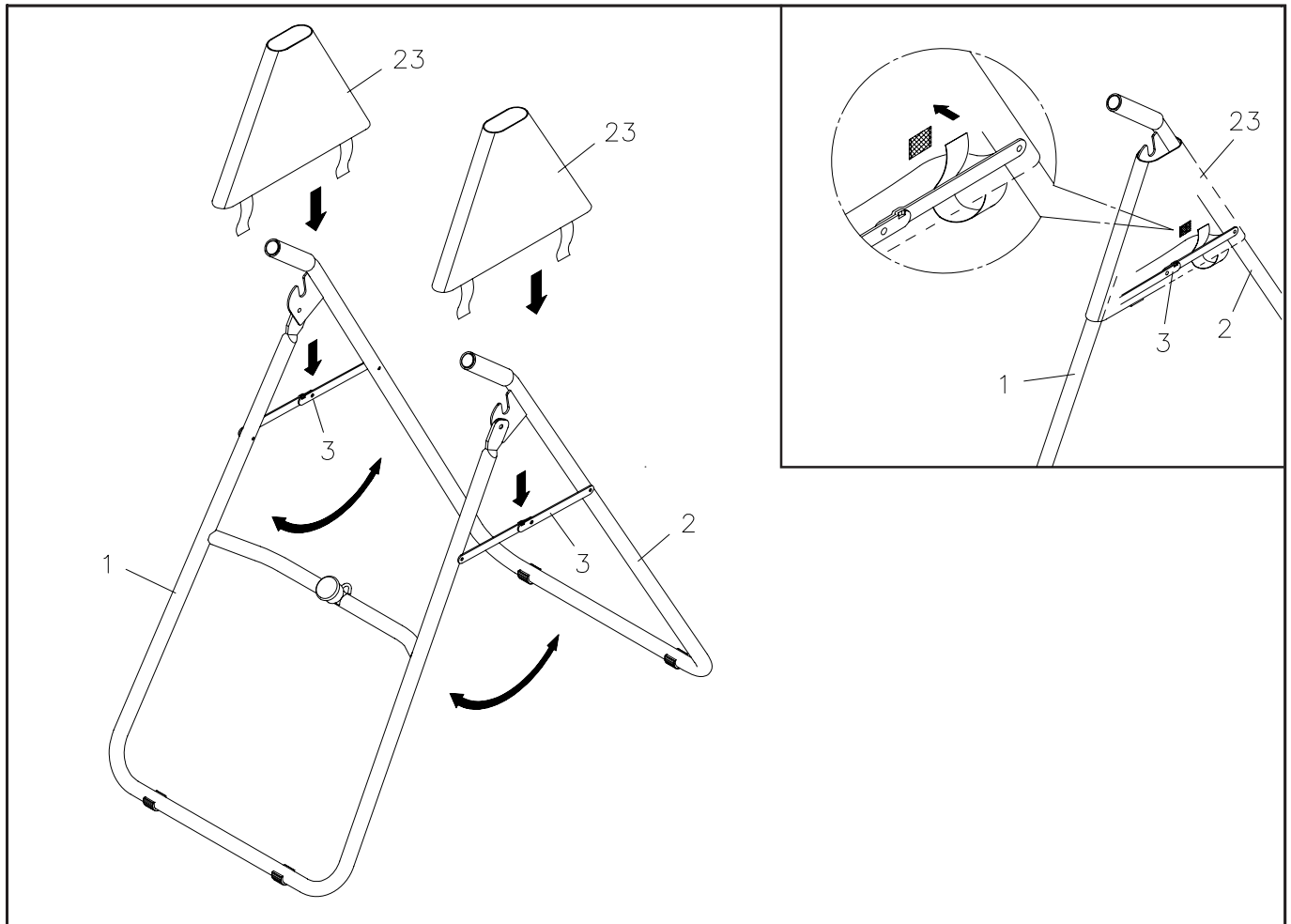

STEP 1

Unfold the **BASE ASSEMBLY** to an upright position by moving the **FRONT FRAME(1)** away from the **REAR FRAME(2)**. Then push down on the middle of the two **FOLDING LINKAGES(3)** until they are fully locked down.

STEP 2

Slide one **PROTECTIVE COVER(23)** onto each side of the **BASE ASSEMBLY**, and pull the covers down until the bottom of the covers are slightly lower than the **FOLDING LINKAGES(3)**. Secure the **PROTECTIVE COVERS(23)** to the **FOLDING LINKAGES(3)** with the **SECURING STRAPS** on the bottom of the covers.

NOTE: When the **PROTECTIVE COVERS(23)** are assembled correctly, the **FOLDING LINKAGES(3)** should not be visible. Refer to the illustration.

ASSEMBLY INSTRUCTIONS

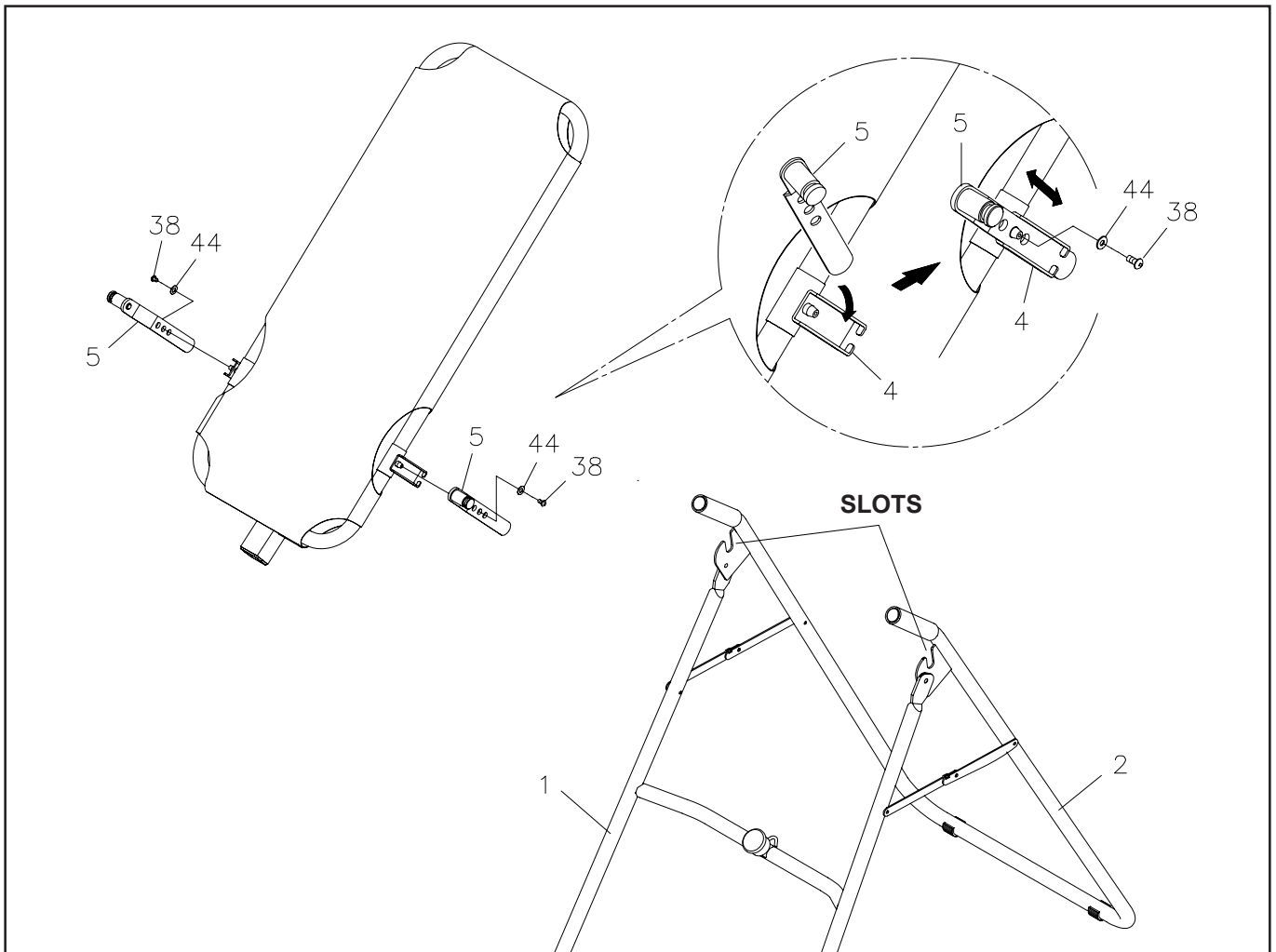

STEP 3

Slide the bottom of the two **PIVOT ARMS(5)** into the brackets located at each side of the **MAIN FRAME(4)**. Align the desired hole on the arm with the peg on the bracket, and insert the peg into the hole to lock the **PIVOT ARMS(5)** in position. Then secure the **PIVOT ARMS(5)** on the pegs with **ROUND HEAD BOLTS (M6x1x10mm)(38)** and **LARGE WASHERS(M6)(44)**.

PIVOT ARM ADJUSTMENT:

There are three adjustment holes on the **PIVOT ARMS(5)** allowing you to position the **MAIN FRAME(4)** at three different heights. The lowest hole will allow the least amount of inversion angle. The top hole will allow the greatest amount of inversion angle.

CAUTION: 1. Use the lowest holes in the **PIVOT ARMS(5)** until you become familiar with the **Gravity Inversion Therapy Table**.

2. Both **PIVOT ARMS(5)** must be adjusted to the same hole. Trying to adjust the **PIVOT ARMS(5)** to different positions could cause damage to the machine, and injury to the user.

STEP 4

Attach the **MAIN FRAME(4)** with the adjusted **PIVOT ARMS(5)** onto the **REAR FRAME(2)** by sliding the slots in the ends of the two **PIVOT ARMS(5)** into the slots on the **REAR FRAME(2)**.

ASSEMBLY INSTRUCTIONS

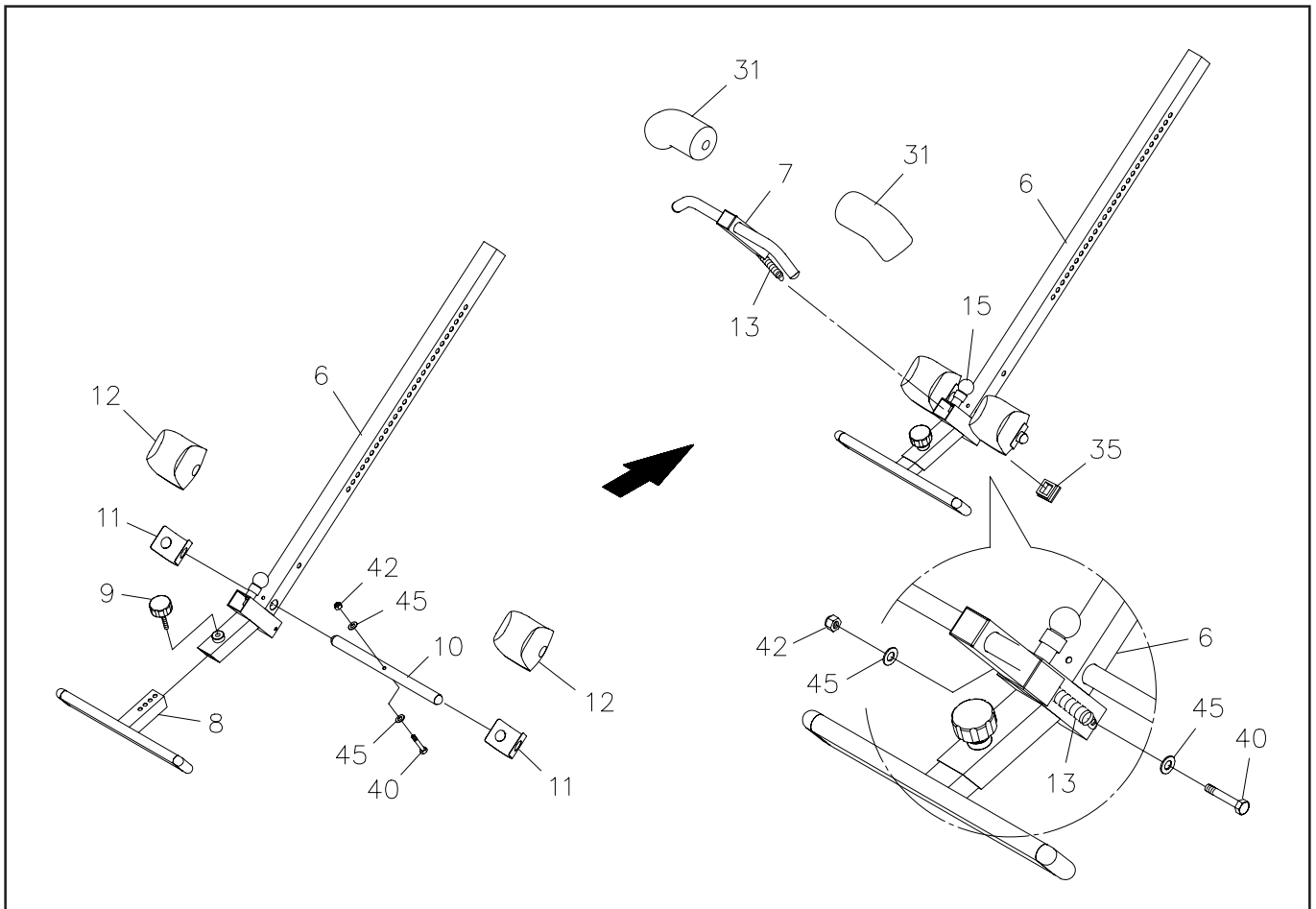

STEP 5

Attach the **FOOTREST(8)** onto the **HEIGHT ADJUSTMENT BEAM(6)** with the **ADJUSTMENT KNOB(9)**.

NOTE: The four adjustment holes in the **FOOTREST(8)** allow the **FOOTREST(8)** to be attached in four different positions. Start with one of the center positions and adjust if necessary. Use the higher position holes if users are taller than average. Use the lower position holes if users are shorter than average.

STEP 6

Insert the **PAD TUBE(10)** through the hole on the **HEIGHT ADJUSTMENT BEAM(6)** and secure with **HEX BOLT(M6x1x47mm)(40)**, **NYLOCK NUT(M6x1)(42)**, and **WASHERS(M6)(45)**. Place a **HEEL HOLDER BRACKET(11)** onto a **HEEL HOLDER(12)**, then slide them onto **PAD TUBE(10)** together. Slide another set of **HEEL HOLDER BRACKET(11)** and **HEEL HOLDER(12)** onto the other end of the **PAD TUBE(10)**.

STEP 7

Attach the **ADJUSTABLE INSTEP FRAME(7)** to the **HEIGHT ADJUSTMENT BEAM(6)** by pulling the **SMALL SPRING PIN(15)** and sliding the **ADJUSTABLE INSTEP FRAME(7)** completely into the **HEIGHT ADJUSTMENT BEAM(6)**. Place a **WASHER(M6)(45)** onto the **HEX BOLT(M6x1x47mm)(40)**, then insert the bolt the halfway through the square tube on the **HEIGHT ADJUSTMENT BEAM(6)**, slide the bolt through the ring at the bottom of the **SPRING(13)**, slide the bolt through the square tube and secure with **NYLOCK NUT(M6x1)(42)** and **WASHER(M6)(45)**. Press the **SQUARE PLUG(35)** into the **HEIGHT ADJUSTMENT BEAM(6)**. Slide the **FOAM PADS(31)** onto both sides of the **ADJUSTABLE INSTEP FRAME(7)**.

ASSEMBLY INSTRUCTIONS

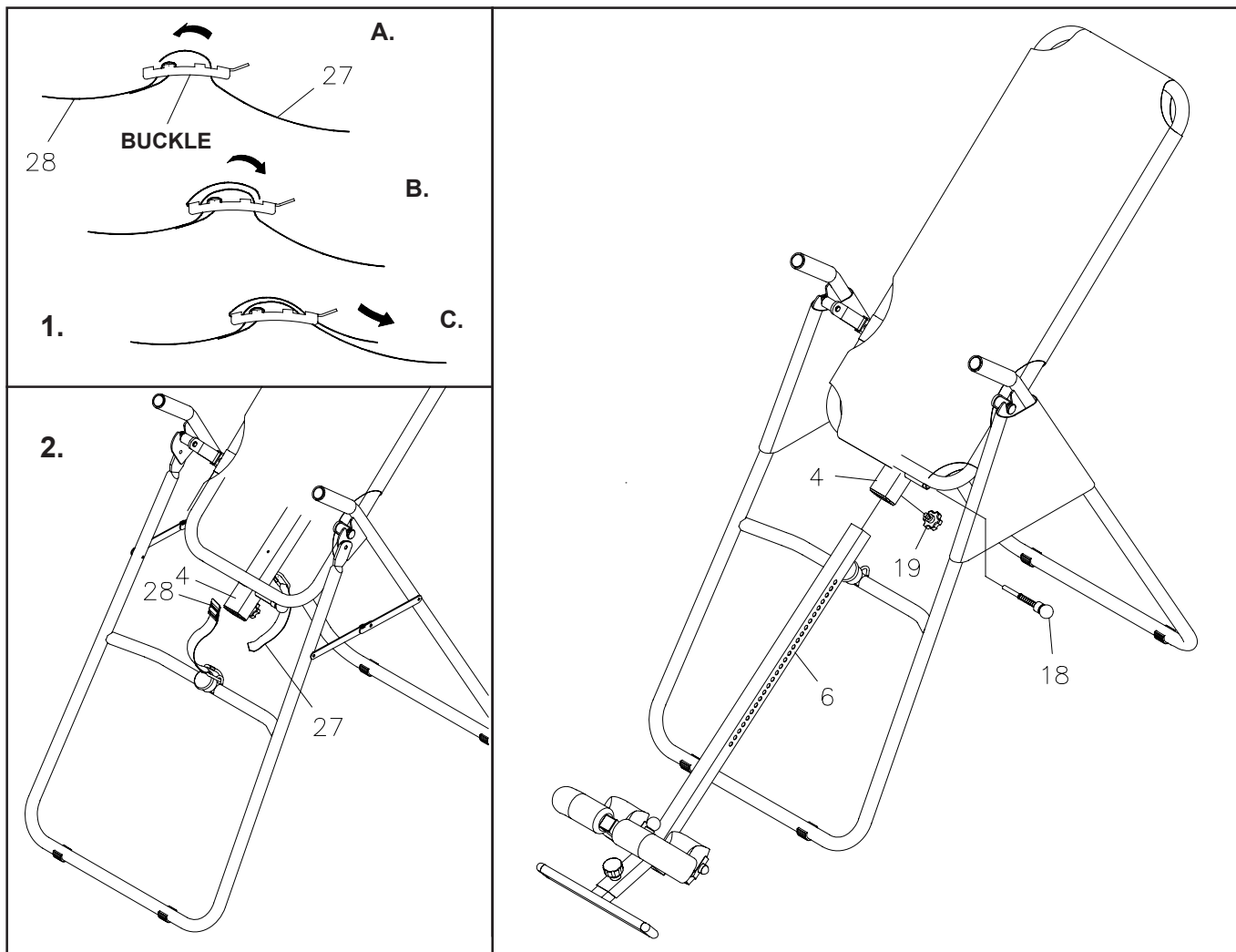

STEP 8

Install the **HEIGHT ADJUSTMENT BEAM(6)** into **MAIN FRAME(4)** by pulling the **LARGE SPRING PIN(18)** on the **MAIN FRAME(4)** and inserting the **HEIGHT ADJUSTMENT BEAM(6)** as shown. For added safety, thread the **LOCKING KNOB(19)** into back side of the **MAIN FRAME(4)**.

WARNING: Do not use the **Gravity Inversion Therapy Table** until you have verified your height setting. Failure to use the proper height setting can result in difficulty recovering from the decline position. See **HEIGHT ADJUSTMENT** instructions on page 10.

STEP 9

Attach the **NYLON STRAP(27)** onto the **BUCKLE** on the end of the **BUCKLE STRAP(28)** by inserting the end of the strap up through the bottom of the buckle, as shown in the illustration 1.

STEP 10

Hook the end of the **NYLON STRAP(27)** onto the loop on the back of the **MAIN FRAME(4)**. Hook the end of the **BUCKLE STRAP(28)** onto the loop on the **FRONT FRAME(1)**.

NOTE: The **NYLON STRAPS** are used to control the decline angle of the **Gravity Inversion Therapy Table**. For a steeper decline angle, lengthen the straps. For a smaller decline angle, shorten the straps. Make sure the **NYLON STRAPS** are tight in the buckle and check the decline angle before using the **Gravity Inversion Therapy Table**.

OPERATIONAL INSTRUCTIONS

GENERAL PRECAUTIONS

1. Use the lowest holes in the **PIVOT ARMS(5)** until you become familiar with the **Gravity Inversion Therapy Table**.
2. Do not use the **Gravity Inversion Therapy Table** alone. Always have a helper available in case assistance is needed in recovering from the decline position.
3. Make sure that the **HEEL HOLDERS(12)** and **FOAM PADS(31)** are holding your feet securely.
4. Make sure that the **HEIGHT ADJUSTMENT BEAM(6)** is properly set for your height.
5. Make sure that the **HEIGHT ADJUSTMENT BEAM(6)** is held securely by both the **LARGE SPRING PIN(18)** and the **LOCKING KNOB(19)**.
6. Make sure that there is enough room for the bed to rotate completely.

HEIGHT ADJUSTMENT

The **Gravity Inversion Therapy Table** is a very sensitive balance device. It responds to very slight changes in weight distribution. It is very important to make sure that the height adjustment is set properly. Use the following procedure to set the height adjustment and balance the **Gravity Inversion Therapy Table**.

1. Adjust the **NYLON STRAPS** to restrict movement to approximately 15 degrees beyond the horizontal position. The nylon straps should not allow the **Gravity Inversion Therapy Table** to go into the full inversion position while you are setting the height adjustment.
2. Loosen the **LOCKING KNOB(19)** under the **MAIN FRAME(4)**.
3. Pull the **LARGE SPRING PIN(18)** and use the **SCALE DECAL(16)** to set the **HEIGHT ADJUSTMENT BEAM(6)**.
4. Tighten the **LOCKING KNOB(19)**.
5. Mount the machine.
6. Lock your ankles into the **HEEL HOLDERS(12)** and **FOAM PADS(31)**.
7. Lie back with your hands at your sides.
8. Slowly raise your hands to your chest.
9. If your feet are higher than your head, dismount and try a taller setting. If you do not rotate to a position close to level, dismount and try a shorter setting.

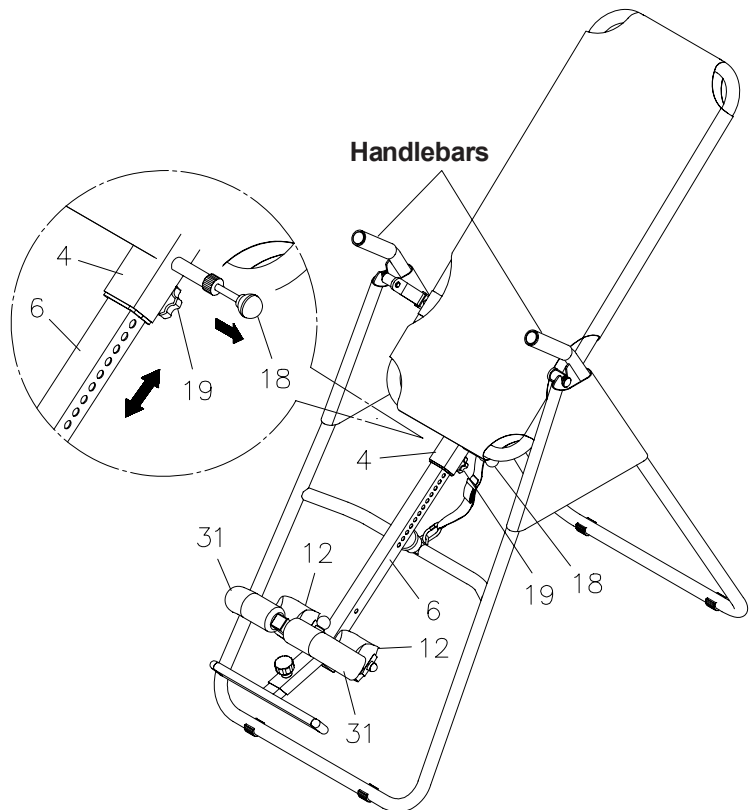

- NOTE:**
1. The **Gravity Inversion Therapy Table** should return to the upright position when your hands are below your waist. If it does not, use a taller setting.
 2. Verify that adequate head clearance is available between the user's head and the floor before using this inversion table. This is especially important for tall users.

THE HANDLEBARS

For added convenience, and safety, a set of **HANDLEBARS** has been added to the **Gravity Inversion Therapy Table**. These **HANDLEBARS** are located at the top of the **REAR FRAME(2)**. The **HANDLEBARS** are to help you return to the upright position from any degree of inversion. If you wish to return to the upright position, and the bed is moving too slowly, or not moving at all, simply grab the **HANDLEBARS** and pull on them until you return to the upright position.

OPERATIONAL INSTRUCTIONS

USING THE INVERSION TABLE

1. Start by lying fully back on the bed with your hands at your side, or resting on your thighs.
2. Keeping your hands close to your body begin to raise your arms slowly allowing the table to rotate backward. Stop, or lower your arms to control the downward rotation of the table.
3. Raise your arms until they are over your head. At this point, the inversion table will be as far back as it can go.
4. As you get more comfortable with the use, rock the bed slowly by moving your arms up and down slowly.
5. A gentle swinging motion will alternately put your spine in traction and compression. This rhythmic type of traction is used by many hospitals and doctors to treat certain back problems.
6. It is recommended that the inversion table be used for five or ten minutes each morning, and again each evening.
7. Return to the upright position by slowly moving your hands back down to your thighs.

1.

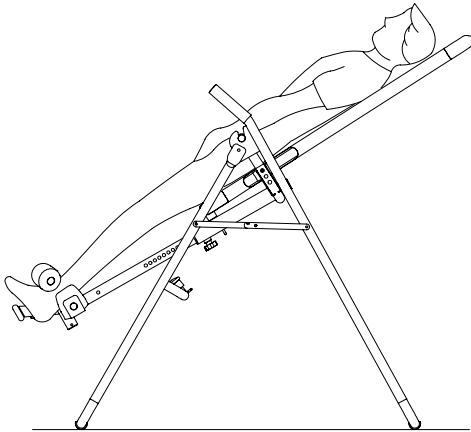

3.

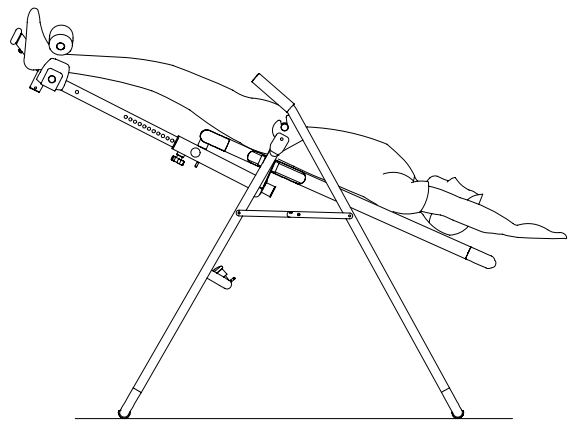

2.

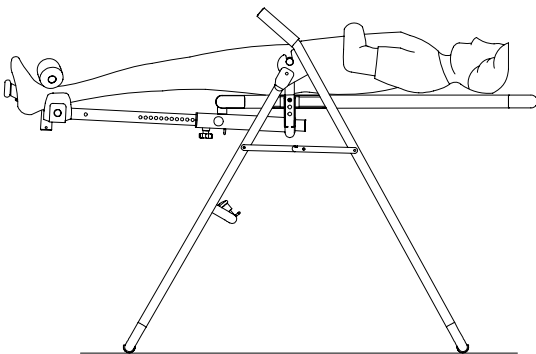

4.

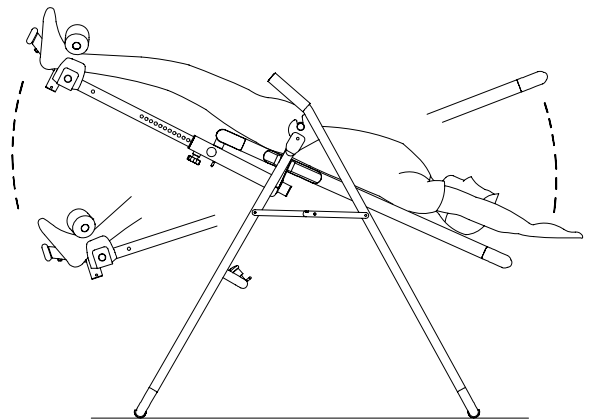

OPERATIONAL INSTRUCTIONS

SUGGESTIONS FOR USE

1. Begin slowly: Invert only 15-20 degrees to begin with. Stay inverted only as long as you are comfortable. Return upright slowly.
2. Make gradual changes: Increase the angle only if it is comfortable. Increase the angle only a few degrees at a time. Increase the time of use 1-2 minutes up to ten over a period of weeks. Add stretching and light exercise only after you are comfortable with inversion.
3. Watch your body: Come up slowly, dizziness after a session means you came up too fast. Wait a while after eating before using table. If you get nauseous, do not fight it, come up as soon as you feel queasy.
4. Keep moving: Movement while inverted encourages blood, lymph, and spinal fluid circulation and aids in alignment of bones and organs. Movement may be accomplished by either rhythmic traction or light exercise. Do not exercise strenuously while inverted. Limit partial inversion without movement to one or two minutes. Limit full inversion with no movement to only a few seconds.
5. Invert regularly: We recommend two or three times a day depending upon your current condition. Try to schedule your inversion sessions for the same times each day.

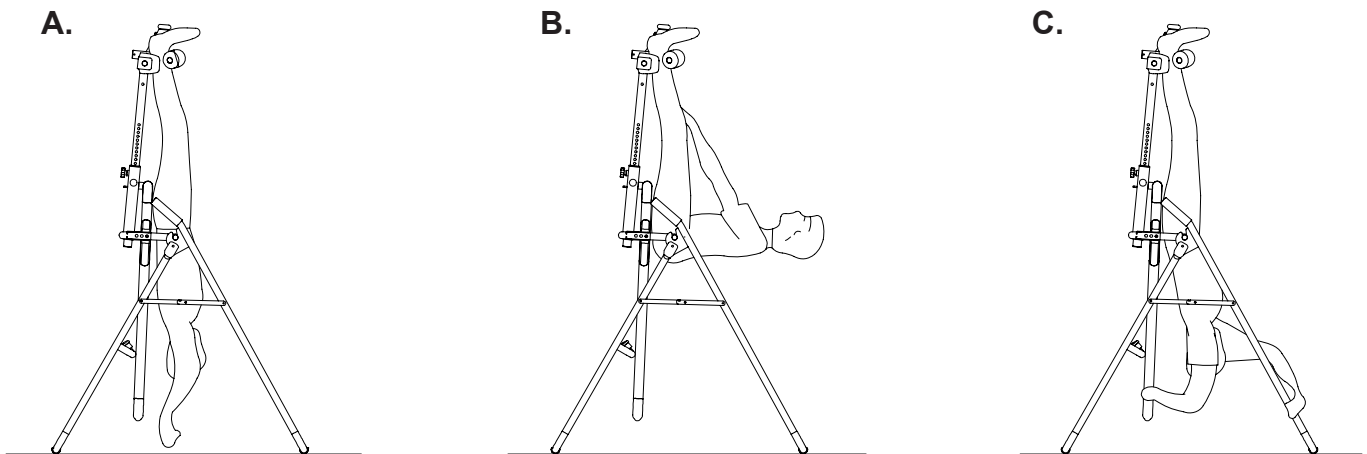

LOCKING THE BED

When the inversion table rotates past the vertical inverted position the bed becomes locked, and will not return to the upright position in the usual way. The locked position allows you to hang straight upside-down completely free of the bed. This position allows you to enjoy all of the benefits of a handstand, with none of the discomforts, as shown in illustration A. It also allows you to do exercises such as the waistbend, as shown in illustration B.

To get into the locked position, use the top hole in the **PIVOT ARMS(5)** as described in assembly **STEP 3**. If necessary, adjust the **HEIGHT ADJUSTMENT BEAM(6)** shorter, and then mount and use normally. When your arms are completely extended above your head, the bed will rotate all the way to the locked position.

CAUTION: You must understand how to recover from the fully inverted position before going fully inverted. Read the **RECOVERY FROM LOCKED POSITION** section below **BEFORE** going fully inverted.

RECOVERY FROM LOCKED POSITION

To recover from the locked position, simply grab the **HANDLEBARS** and pull on them while pushing back on the **HEEL HOLDERS(12)** with your legs. If you cannot reach the **HANDLEBARS**, then you can still recover by grabbing the back of the bed with one hand, the **REAR FRAME(2)** with the other, and pulling your hands together, as shown in illustration C.

STORAGE

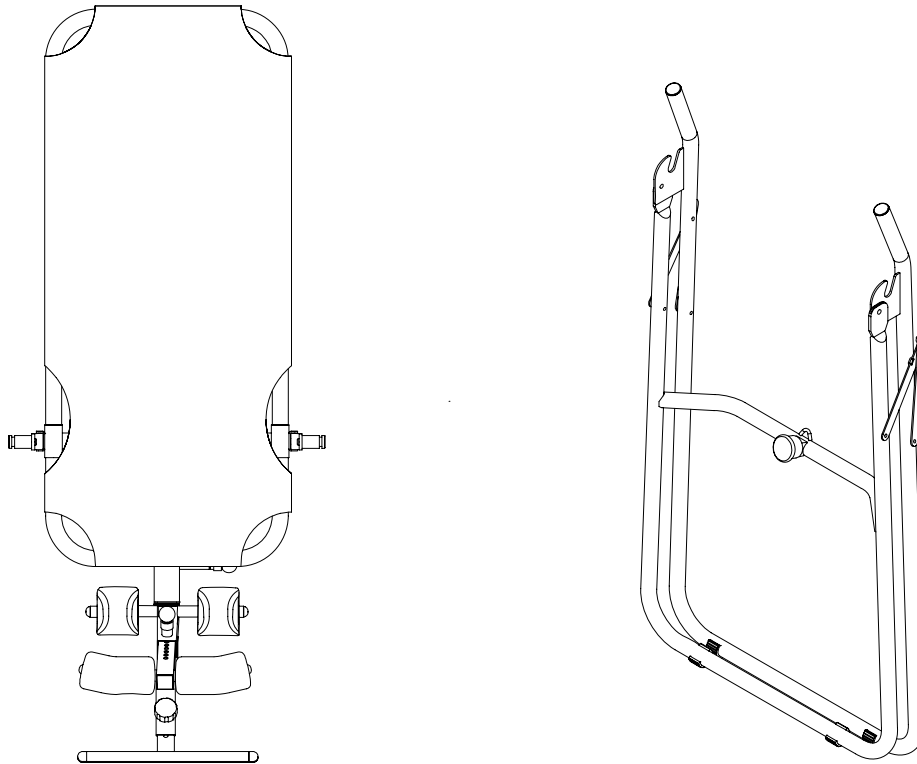

FOLDING THE INVERSION TABLE

The **Gravity Inversion Therapy Table** can be easily folded for storage.

To fold the **Gravity Inversion Therapy Table** loosen the **LOCKING KNOB(19)** and pull out the **LARGE SPRING PIN(18)**. Now, slide the **HEIGHT ADJUSTMENT BEAM(6)** all the way up into the **MAIN FRAME(4)** until the **ADJUSTABLE INSTEP FRAME(7)** is just below the **MAIN FRAME(4)**, release the **LARGE SPRING PIN(18)** and slide the **HEIGHT ADJUSTMENT BEAM(6)** slightly up or down until the spring pin locks the beam in place. Remove the **MAIN FRAME ASSEMBLY** from the **BASE** by lifting up on the **MAIN FRAME(4)** until the **PIVOT ARMS(5)** come out of the slots located at the top of the **REAR FRAME(2)**, (Make sure the **NYLON STRAP** is not attached to the **MAIN FRAME(4)** before attempting to remove it.) Push up on the center of the **FOLDING LINKAGES(3)** and push the **FRONT FRAME(1)** and **REAR FRAME(2)** together until they meet.

MAINTENANCE INSTRUCTIONS

The safety level of the **Gravity Inversion Therapy Table** can be maintained only if it is examined regularly for damage and wear.

1. Check the warning label, nylon strap, strap buckle, pivot arms, nylon bed, Foam Pads, heel holders, small spring pin and large spring pin for damage and wear.
2. Replace damaged and worn components immediately and/or keep the equipment out of use until repairs are completed.

PARTS LIST

DIAGRAM#	PART NAME	QTY
1	Front Frame	1
2	Rear Frame	1
3	Folding Linkage	2
4	Main Frame	1
5	Pivot Arm	2
6	Height Adjustment Beam	1
7	Adjustable Instep Frame	1
8	Footrest	1
9	Adjustment Knob	1
10	Pad Tube	1
11	Heel Holder Bracket	2
12	Heel Holder	2
13	Spring	1
14	Roll Pin	1
15	Small Spring Pin	1
16	Scale Decal	1
17	Bushing	2
18	Large Spring Pin	1
19	Locking Knob	1
20	Foam Cushion	1
21	Double sided Tape	1
22	Nylon Bed	1
23	Protective Cover	2
24	Hand Grip	2
25	Bumper	1
26	Hook	2
27	Nylon Strap	1
28	Buckle Strap	1
29	Hollow Cap	1
30	Stand	4
31	Foam Pad	2
32	Dome Plug (22.2mm)	4
33	Round Plug (31.8mm)	2
34	Square Plug (33.4mm x 33.4mm)	1
35	Square Plug (38mm x 38mm)	2
36	Oval Plug (20mm x 60mm)	2
37	Support Washer	1
38	Bolt, Round Head (M6 x 1 x 10mm)	2
39	Bolt, Round Head (M6 x 1 x 40mm)	4
40	Bolt, Hex Head (M6 x 1 x 47mm)	2
41	Bolt, Hex Head (M8 x 1.25 x 25mm)	2
42	Nylock Nut (M6 x 1)	2
43	Nylock Nut (M8 x 1.25)	2
44	Large Washer (M6)	2
45	Washer (M6)	16
46	Washer (M8)	4
47	Plastic Washer (M8)	2
48	Warning Label	1
49	Wrench	1
50	Combination Wrench	1
51	Manual	1
52	Lock Washer (M6)	4
53	Acorn Nut (M6 x 1)	4

WARRANTY

Stamina Products, Inc. warrants that this product will be free from defects in materials and workmanship under normal use, service and proper operation for a period of 90 days on the parts and 3 years on the frame from the date of the original purchase from an authorized retailer. **THIS WARRANTY SHALL NOT APPLY TO ANY PRODUCT WHICH HAS BEEN SUBJECT TO COMMERCIAL USE, ABUSE, MISUSE, ALTERATION OF ANY TYPE OR CAUSE OR TO ANY DEFECT OR DAMAGE CAUSED BY REPAIR, REPLACEMENT, SUBSTITUTION OR USE WITH PARTS OTHER THAN PARTS PROVIDED BY STAMINA PRODUCTS, INC.** Commercial use includes use of the product in athletic clubs, health clubs, spas, gymnasiums, exercise facilities, and other public or semipublic facilities whether or not the product's use is in furtherance of a profit making enterprise, and all other use which is not for personal, family, or household purposes.

To implement this limited warranty, send a written notice stating your name, date, and place of purchase and a brief description of the defect along with your receipt to **Stamina Products, Inc. PO. Box 1071, Springfield Missouri, USA, 65801-1071** or call us at **1 (800) 375-7520**. If the defect is covered under this limited warranty, you will be requested to return the product or part to us for free repair or replacement at our option. **NO ACTION FOR BREACH OF THIS LIMITED WARRANTY MAY BE COMMENCED MORE THAN ONE (1) YEAR AFTER THE DATE THE ALLEGED BREACH WAS OR SHOULD HAVE BEEN DISCOVERED. NO ACTION FOR BREACH OF ANY IMPLIED WARRANTY MAY BE COMMENCED MORE THAN ONE (1) YEAR AFTER DELIVERY OF THE PRODUCT TO THE PURCHASER.** This limited warranty is not transferable. **IF ANY PART OF THE PRODUCT IS NOT IN COMPLIANCE WITH THIS LIMITED WARRANTY OR ANY IMPLIED WARRANTY, THE REMEDY OF REPAIR OR REPLACEMENT IS THE EXCLUSIVE REMEDY AVAILABLE TO YOU.** In the event that the purchaser makes any claim under this limited warranty or any implied warranty, the Warrantor reserves the right to require the product to be returned for inspection, at the purchaser's expense, to the Warrantor's premises in Springfield, Missouri. Return of the enclosed warranty registration card is not required for warranty coverage, but is merely a way of establishing the date and place of purchase.

Stamina Products, Inc. **SHALL NOT BE LIABLE FOR THE LOSS OF USE OF ANY PRODUCT, LOSS OF TIME, INCONVENIENCE, COMMERCIAL LOSS OR ANY OTHER INDIRECT, CONSEQUENTIAL, SPECIAL OR INCIDENTAL DAMAGES DUE TO BREACH OF THE ABOVE WARRANTY OR ANY IMPLIED WARRANTY.**

This limited warranty is the only written or express warranty given by Stamina Products, Inc. This warranty gives you specific legal rights, and you may also have other legal rights which vary from state to state. **ANY OTHER RIGHT WHICH YOU MAY HAVE, INCLUDING ANY IMPLIED WARRANTY OR MERCHANTABILITY OR FITNESS FOR A PARTICULAR PURPOSE, IS LIMITED IN DURATION TO THE DURATION OF THIS WARRANTY.**

The laws in some jurisdictions restrict the rights of manufacturers and distributors of consumer goods to disclaim or limit implied warranties and consequential and incidental damages with respect thereto. If any such law is found to be applicable, the foregoing disclaimers and limitations of and on implied warranties and consequential and incidental damages with respect thereto shall be disregarded and shall be deemed not to have been made to the extent necessary to comply with such legal restriction.

NOTES

